

# Moulded Cords & Cables Ltd Product Fact sheet.

## MCC REF: STK954

Description: C6 Screw-fit inlet black

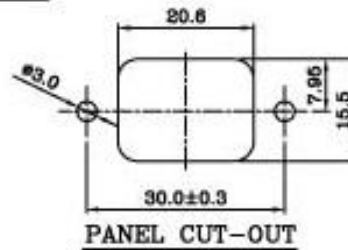
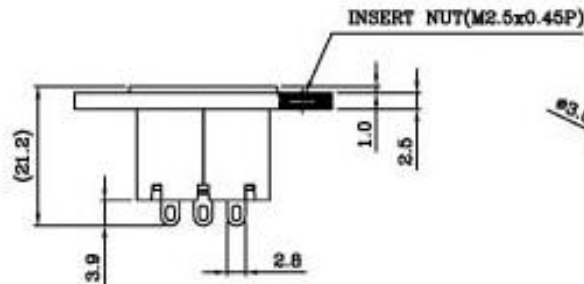
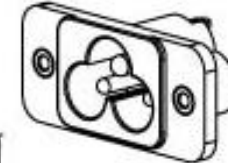
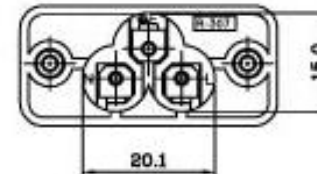
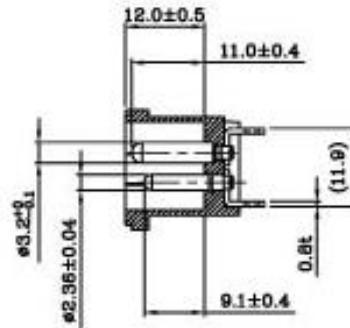
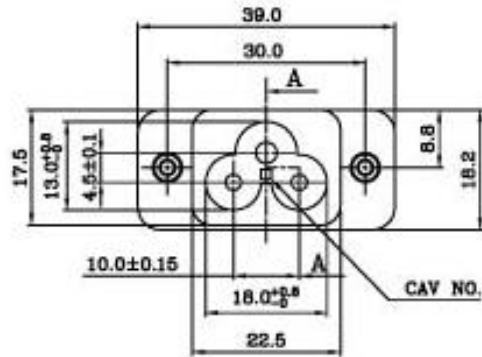

### SPECIFICATION:

1. Insulation Resistance: Over 100M $\Omega$  at 500V
2. Dielectric strength: 2000V AC 1 Minute.
3. Body Material: Thermoplastic 94V-2-V-0.

DO NOT SCALE, DIMENSIONS FOR REFERENCE ONLY